

# **GUHRING**

# **MQL**

**BY GUHRING**



## **Minimum Quantity Lubrication Basics**

GUHRING - YOUR WORLD-WIDE PARTNER



With the development of the first MQL delivery system, Guhring pioneered the reduction in coolants and lubricants in the metal cutting industry.

Our MQL machining program includes MQL chucks for 1-channel and 2-channel systems as well as additional chucks and accessories. Furthermore, we provide MQL-suitable tools and specifically developed inspection equipment for checking, evaluating, optimising and documenting the efficiency of tool lubrication systems.

This handbook contains detailed information regarding MQL technology, its technical implementation into different configurations, associated MQL-suitable tools with accessories, the MQL test station as well as the MQL-Check 3000 equipment.

## CONTENTS

	<b>Page</b>
ML - technology and advantages	4
Tools for ML machining	6
Systems for ML machining	10
ML by Guhring	12
ML-Check 3000	14
ML test station	15

## Introduction

Minimal quantity lubrication (MQL) works with an air lubrication mixture (aerosol) containing only a very small proportion of cooling lubricant (CL). Minute drops of cooling lubricant are applied directly to the cutting edge. The targeted application creates an optimal film of lubricant between tool, workpiece and chip, minimising the friction heat already prior to its creation or dissipate it via the chip respectively. When optimally adjusted, MQL is a loss or consumption of lubrication. This means that close to 100% of the aerosol evaporates in the effective area.

## Internal and external delivery

There are two possibilities for delivering the cooling lubricant to the effective work area. Firstly via external delivery where the cooling lubricant is provided to the tool point by an external nozzle. Secondly through internal delivery where the cooling lubricant is transported via coolant ducts through the machine spindle, the chuck and the tool to ensure optimal lubrication of the effective area.

With internal delivery it is especially important for the aerosol to pass through the machine spindle and reach the exit at the tool point free of lubricant globules. Thus, all the components from the MQL system to the clamping system and the tool geometry must be optimally adjusted.

## 1- and 2-channel system

MQL systems are subdivided into 1- and 2-channel systems. With 1-channel systems the aerosol is mixed outside of the spindle and transported to the tool point via an external supply line.

A 2-channel system mixes the aerosol directly at the tool holder after the lubricant and air is delivered separately via two channels through the tool spindle to the tool holder.

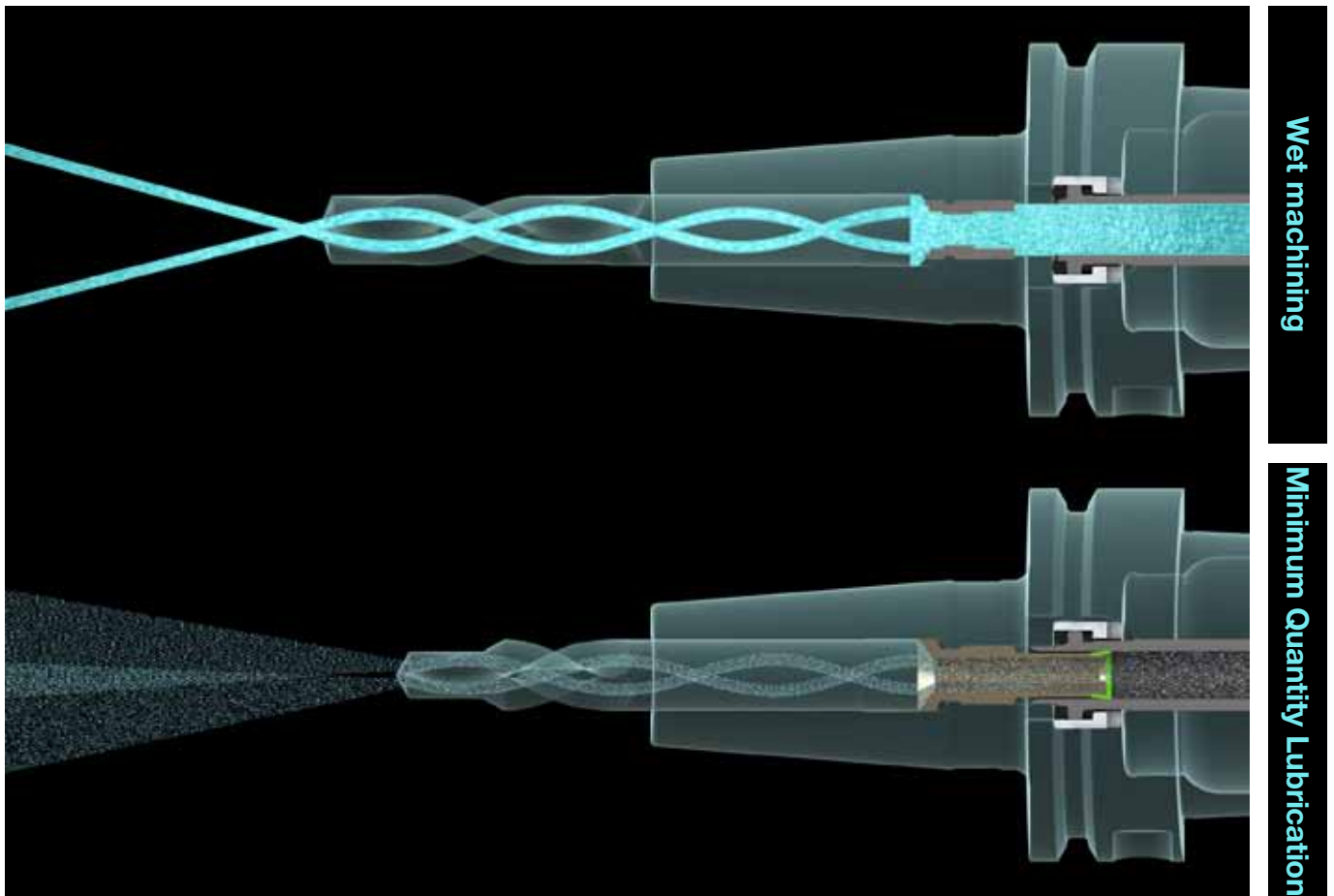

## The aim of MQL machining

- reduction of thermal stresses at the tool point
- less tool wear
- effective chip evacuation from deep holes
- reduction of cooling lubricant requirement (MQL CL requirement 0.025 l/h)
- high cooling and lubrication effect especially in deep holes
- reduction in component cleaning costs
- reduction in cooling lubricant disposal costs
- reduction in cost of disposal of swarf contaminated with cooling lubricant
- protection of environment and health through lower emissions

## Reduction of cooling lubricant requirement

Alongside the machine and tooling the costs for coolant are a considerable portion of the overall cost of the machining process. Therefore, a reduction in the cooling lubrication requirements offers a potential for cost savings.

In comparison to wet machining, minimal quantity lubrication only uses low quantities of CL. Only the amount of oil actually required is applied and directly sprayed onto the effective area on the workpiece. Instead of up to 1,000 litres minimal lubrication manages with only a spirit glass (0.025 l/h) of lubricant per hour.

The reduction of cooling lubricants is not only cost saving but is also of benefit to the environment and health protection because fewer emissions are released with MQL machining.

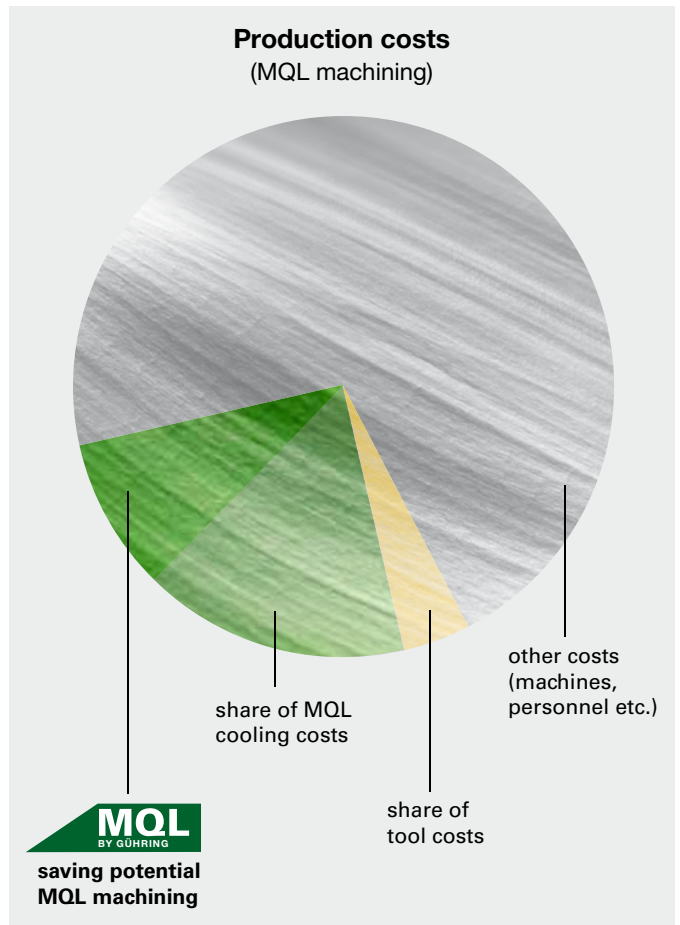
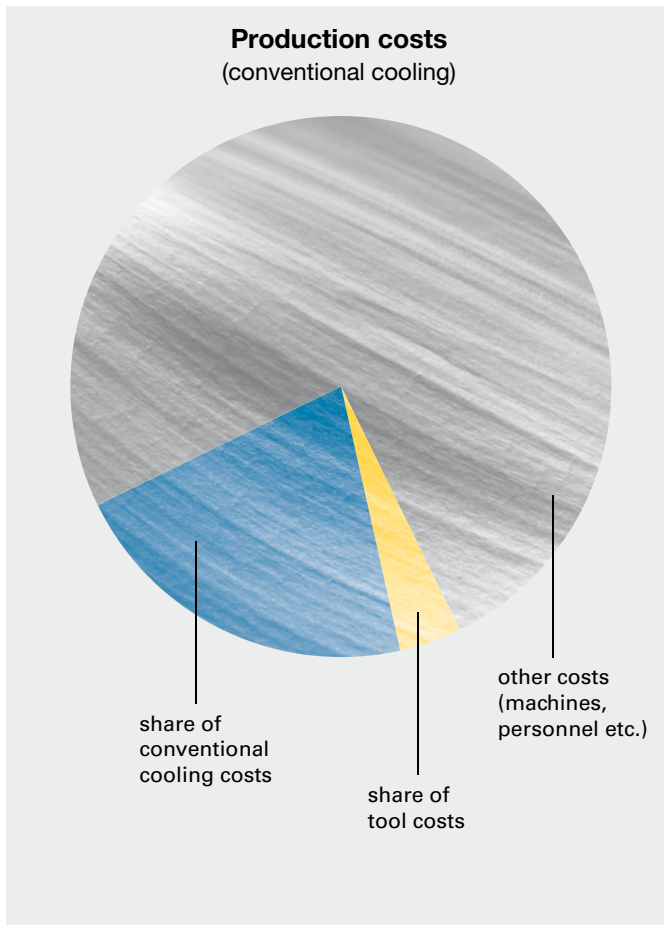

## Optimal form for MQL

Because with dry and MQL machining, any generated heat is not dissipated via coolant like with conventional wet machining, the design of the optimised tool must ensure that

- heat generation is minimised during the machining process (i.e. through sharp cutting edges and a positive rake angle whilst increasing the cutting parameters),
- friction is minimised (i.e. through a width reduction of the leading margins in comparison to the wet tool and increasing the back taper of the tool),
- heat transfer between chip and tool is reduced (i.e. through heat insulating hard coatings and polished tool surfaces to reduce the friction between chip and face),
- heat transfer between chip and workpiece is reduced (i.e. through improved chip evacuation from the hole or from the workpiece surface respectively).

A professional approach during the design of MQL suitable tools nowadays allows considerable performance increases whilst maintaining process reliability. Hereby, all the drill's relevant attributes for providing efficiency and process reliability, from the cutting edge to the flute as well as the shank end, are adapted to satisfy the special demands of MQL. As well as the choice of carbide, this also includes the special tool geometry, the tool coating and the design of the shank end for MQL drills.

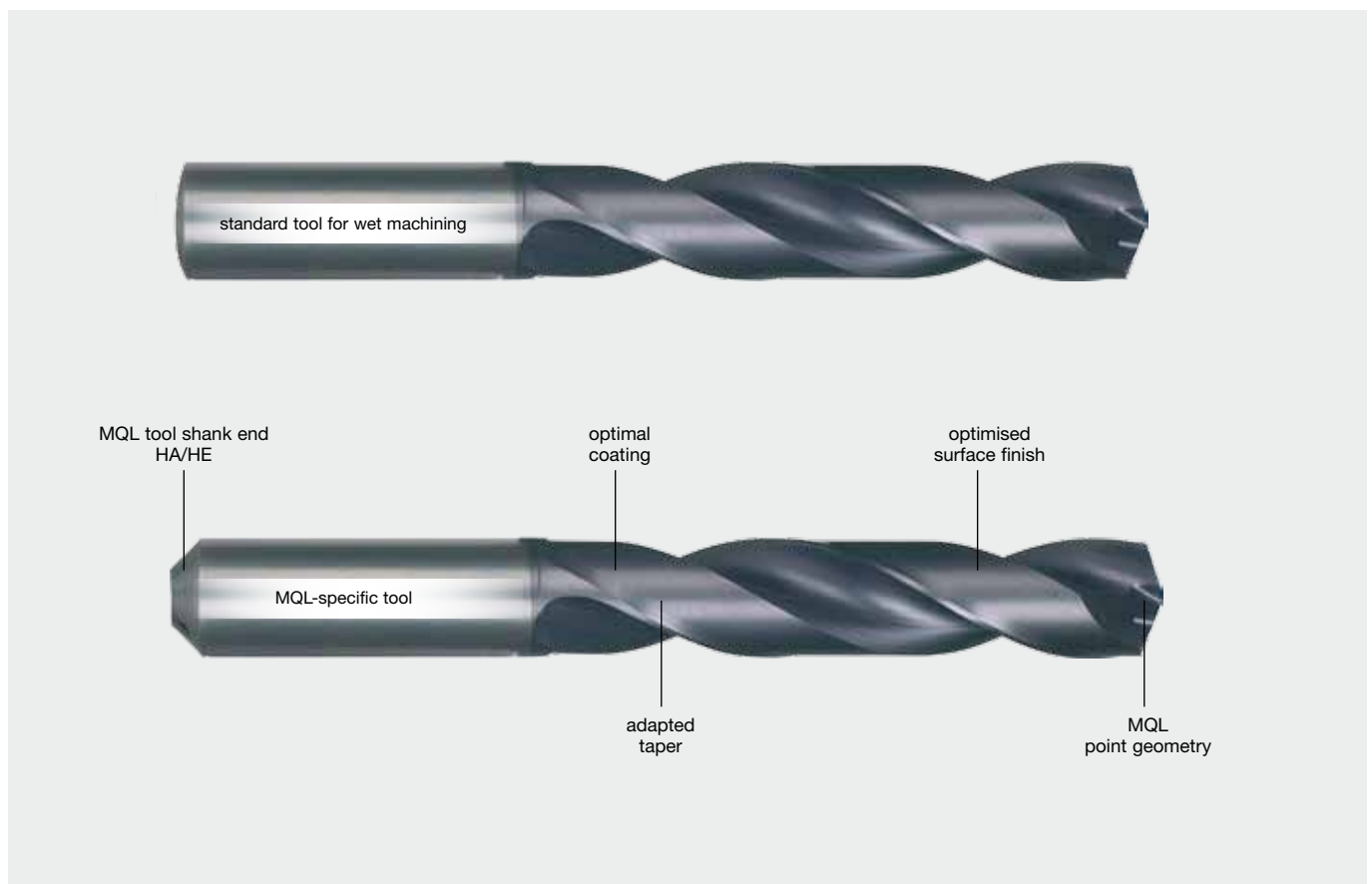

## Coolant delivery to suit MQL

Because an extremely low volume of lubricant is applied with minimal quantity lubrication, the delivery of these low coolant quantities to the effective area is of utmost importance. Hereby, the geometric design of the shank end is of main significance for a safe delivery of the lubricant.

In order to guarantee efficiency and process reliability the following basic requirements must be implemented:

- minimal dead areas that could lead to consolidation of coolant
- sealed coolant transfer surface between shank end and delivery screw preventing the escape of coolant in the clamping area of the chuck or in the internal areas of HSK (preventing swarf deposits that could lead to concentricity errors following the next tool change)
- simple handling
- cost-effective production

In order to satisfy the demand for more efficiency and process reliability with MQL drilling operations, Guhring has examined the design of the shank end and subsequently the coolant delivery in great detail.

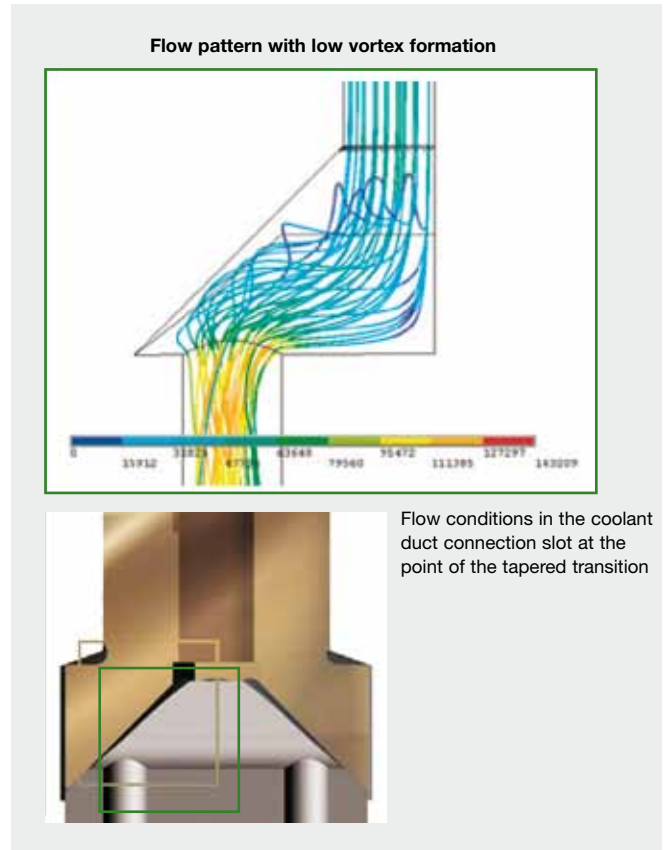

## MQL-optimised chip evacuation

### Flute design to suit MQL

The flute in the area directly behind the cutting edge has the task to mould the chip in order to break it as small as possible. In the rear area its task is to evacuate the chip as quickly as possible. These tasks apply to wet machining, minimal quantity lubrication as well as dry machining. With minimal quantity lubrication and dry machining, however, it is extremely important to provide the chip with minimal frictional resistance in the rear area, in order to ensure a problem-free chip evacuation. This is aided by an optimised flute form as well as a specially polished flute surface.

### Coating to suit MQL

In addition, improved chip evacuation and therefore increased process reliability is provided by a MQL-suitable coating. Guhring has developed a double coating, consisting of a hard coating with an additional soft coating. This double coating is mainly used for steel and cast machining.

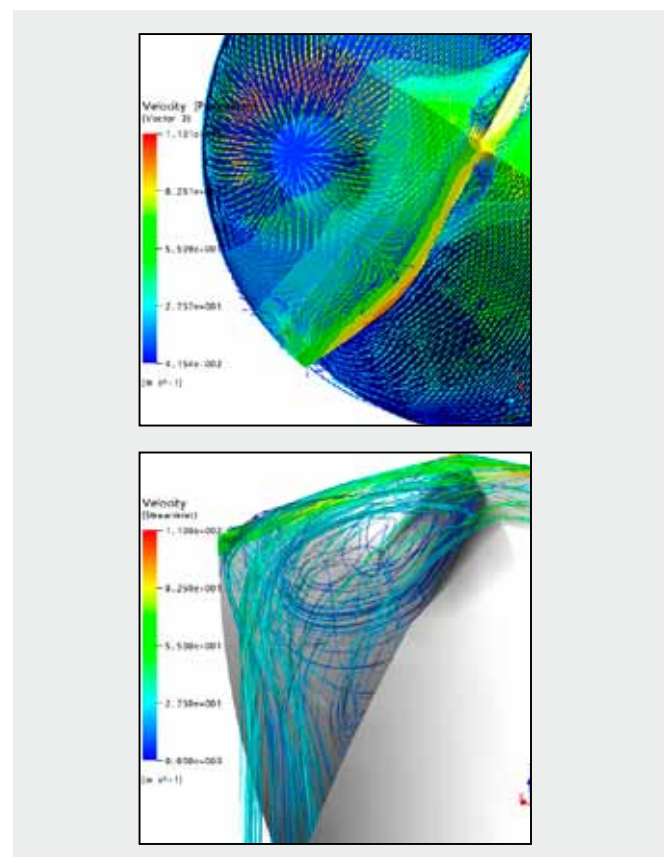



# Cylinder head

(complete MQL machining)



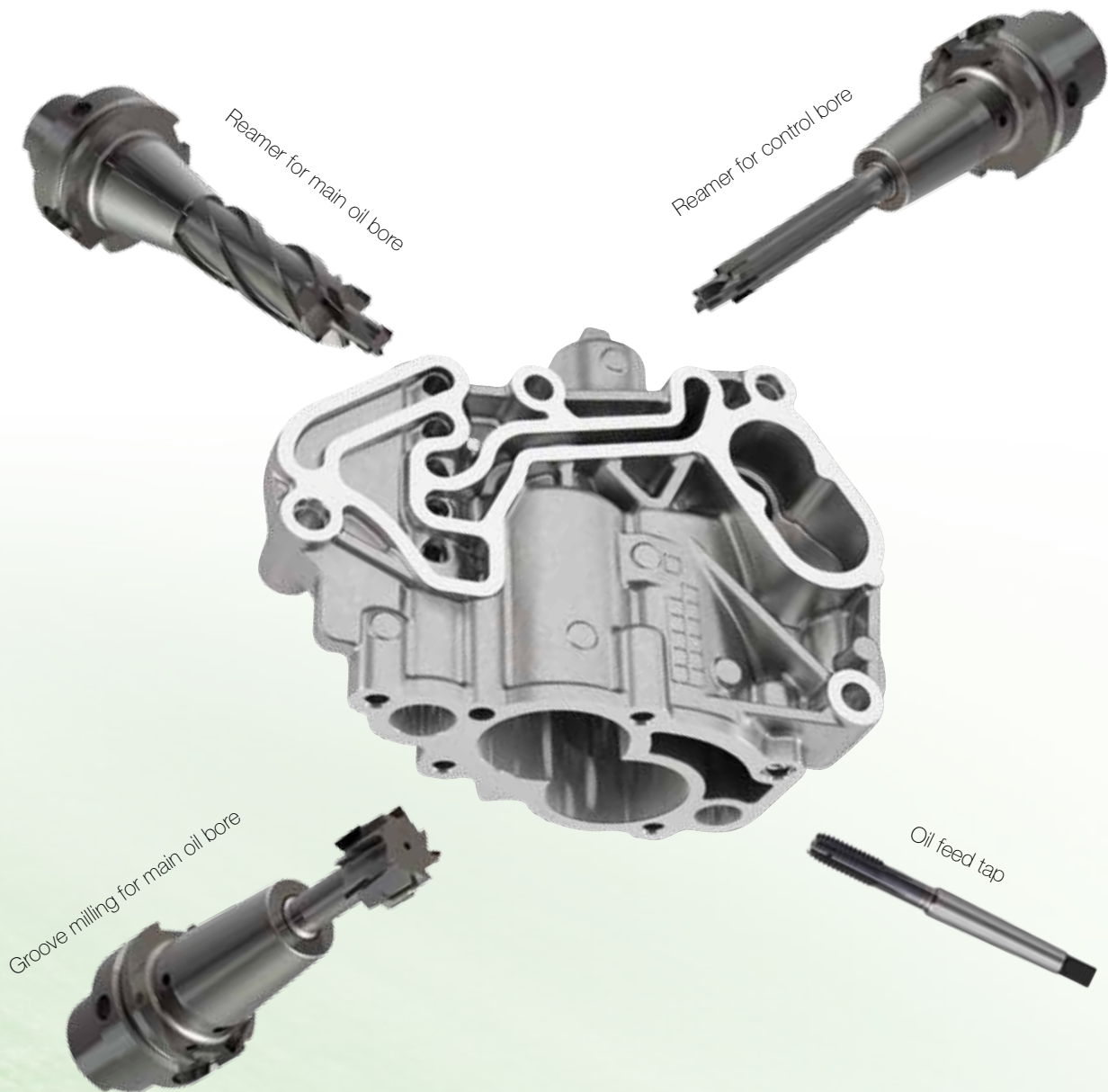

## Pump housing

(complete MQL machining)

# SYSTEMS FOR MQL MACHINING

The provision of the MQL medium via the tool enables accurate delivery of the aerosol directly to the effective area. This ensures optimal delivery of the cooling lubricant independent of the accessibility of the machining location.

Thus, large drilling depths and high cutting speeds can be achieved. MQL systems with internal cooling lubricant delivery are divided into 1-channel and 2-channel systems.

## 1-channel MQL system

With a 1-channel system, the aerosol is mixed in an external MQL unit. The air-oil-mixture is transported directly to the

tool via the aerosol line, the rotary adaptor and the spindle. Only a supply line is required.

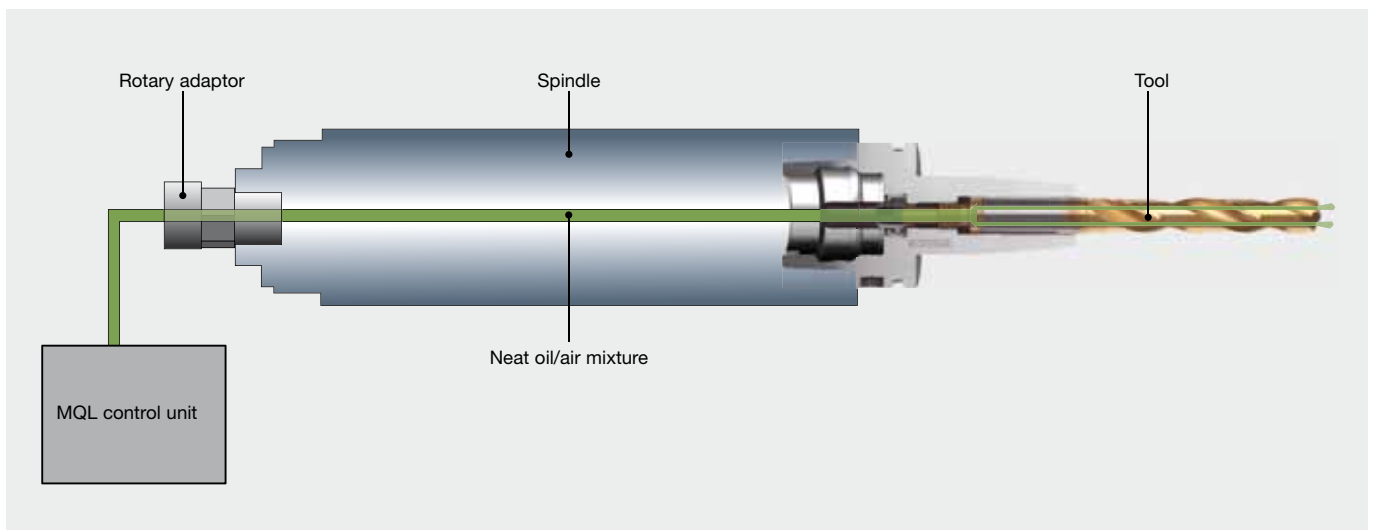

## 2-channel MQL system

With a 2-channel system cooling lubricant and air are separately transported via two channels through the tool spindle to the tool holder and then mixed there. A spindle mounted lance suppresses the centrifugal effect and therefore the possibility of de-mixing processes in the spindle. In comparison to the 1-channel system the spindle speed can be increased considerably.

An integrated quick valve system controls the optimal dosage of oil volume. Oil and air can be mixed in almost unlimited quantities with this system. The route from the mixing chamber to the point of destination is only minimal resulting in a rapid response time and allowing a very quick alteration of the volume of neat oil.

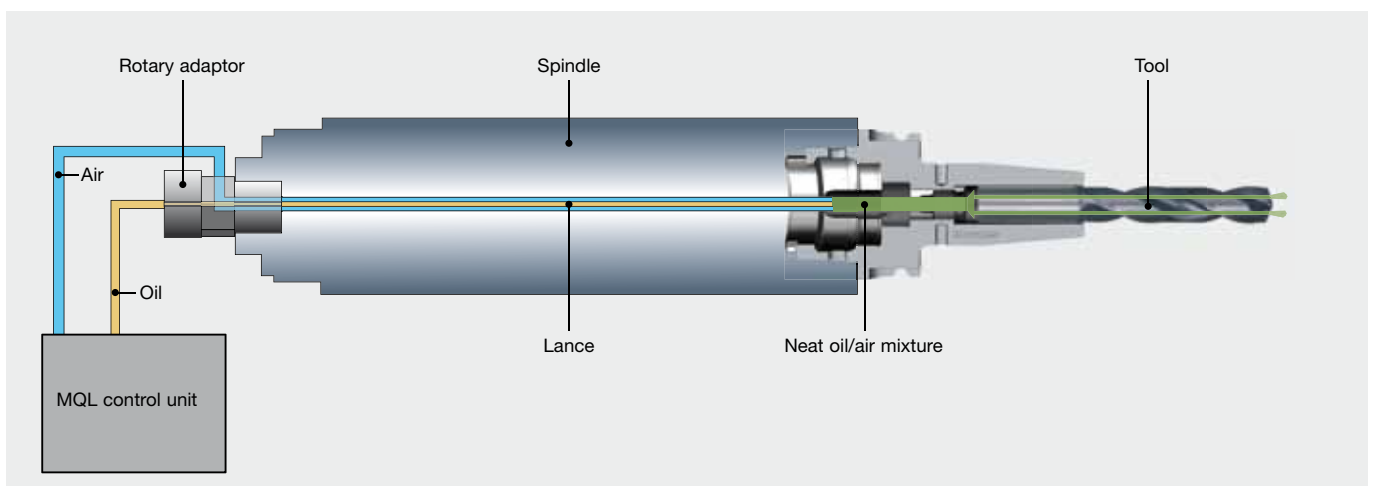

## 1-channel MQL system

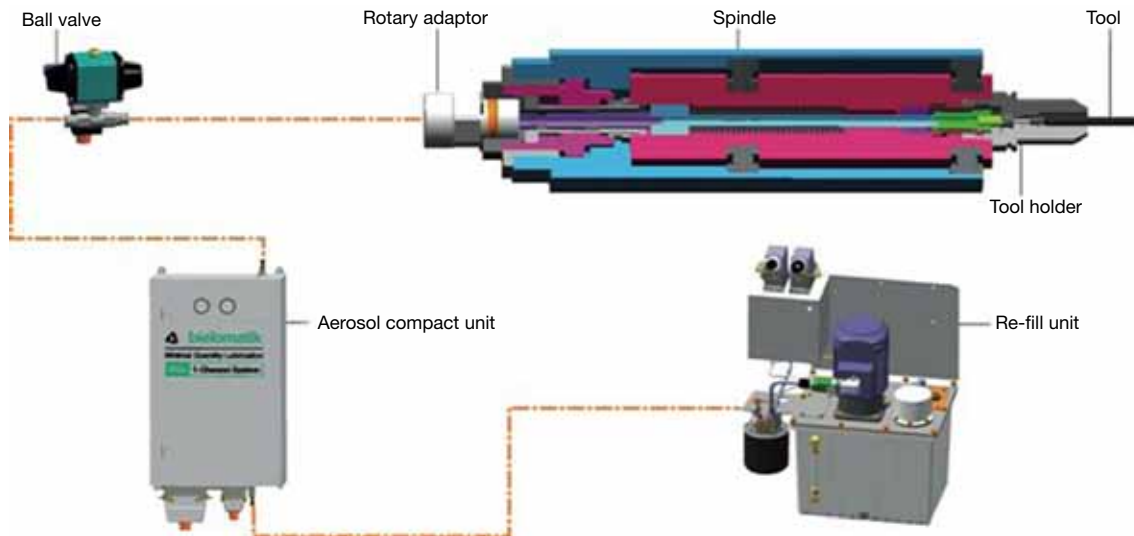

Graphic: Bielomatik

## 2-channel MQL system

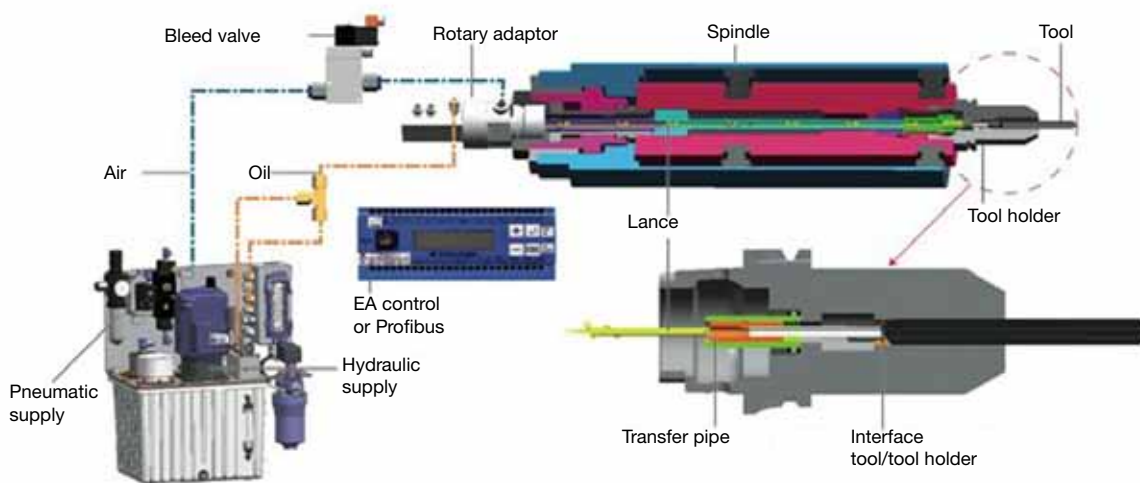

Graphic: Bielomatik

The fact that MQL technology has been widely accepted as a practical solution was thanks to Guhring's active research and development. From clamping sets to tool geometries all features were included in the scope of the development.

**Guhring's MQL program includes:**

- MQL suitable tools with optimised dry machining properties
- hydraulic chucks, shrink fit chucks and synchro chucks for 1-channel and 2-channel systems
- length setting screws and the respective sealing features
- coolant delivery sets and assembly adapters
- MQL Check 3000 measuring equipment for quantitative and time-function inspection of the MQL aerosol flow behaviour
- The MQL test station for the investigation, evaluation and optimisation of the functional capability of the tool lubrication

## 1 MQL BY GÜHRING

Our products for the MQL 1-channel technology are identified by this symbol.

**Visual feature of the 1-channel system** is the gold coloured MQL length setting screw.



## 2 MQL BY GÜHRING

Our products for the MQL 2-channel technology are identified by this symbol.

**Visual feature of the 2-channel system** is the black coloured MQL length setting screw.



# MQL SYSTEM FINDER

			HSK-A for automatic tool change	HSK-A for manual tool change
<b>1</b> <b>MQL</b> BY GÜHRING	Hydraulic chucks		4210	4209
	Shrink fit chucks		4741	4735
	Synchro-chucks		4330	4298
<b>2</b> <b>MQL</b> BY GÜHRING	Hydraulic chucks		4612	4611
	Shrink fit chucks		4614	4613
	Synchro-chucks		4341	4298

automatic tool change

manual tool change

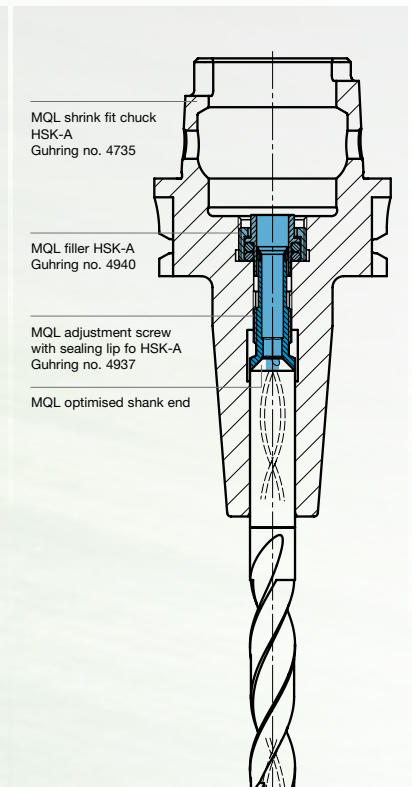
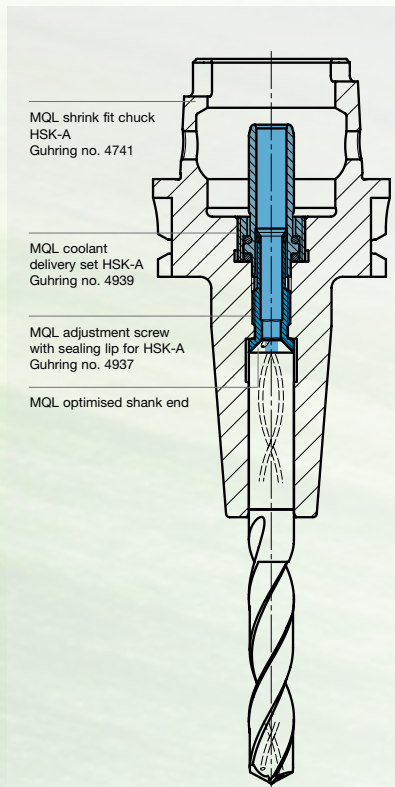

## Measurement taken directly at the tool point

Especially with minimal quantity lubrication, an optimal delivery of the minimal coolant volume to the cutting edge is paramount. An insufficient delivery or a delayed response time respectively can lead to fatal results such as premature wear, a deterioration in machining quality or even tool breakage. However, a too large quantity of CL results in increased costs through unnecessary lubricant consumption and additional cleaning expense for components and machines respectively.

With the MQL Check 3000, Guhring provides an easy to operate measuring device for quickly checking the cooling lubricant volume directly at the tool point.

## Function and application

MQL-Check 3000 is simply installed in the machine, the tool point is passed into the measuring opening of the measuring unit and the coolant delivery switched on. The measuring unit of the MQL-Check 3000 sends the recorded data wireless to the associated display equipment, on which the resulting values are displayed in ml/h. Furthermore, the data interface on the display facility allows the transfer of the data to a PC as an option, making further evaluations and above all the documentation of the measurements possible.



## Advantages of MQL Check 3000

- simple, quick measuring of the coolant volume directly at the tool point
- ascertaining the actual response time, i.e. the time from starting the system to the coolant exiting at the tool point
- reproduceable and at any time comparable measuring data
- a workshop suitable system, wireless operation - in terms of power supply as well as data transfer
- comparative measuring regarding function of MQL equipment, machine, spindle, tool holder and tool

## Technical Data

Measuring range	5 to 60 ml/h
Tool diameter range	3 to 20 mm
Measuring position	0 to 90° (vertical and horizontal machining)
Power supply	battery

## MQL-Check 3000 consists of:

- measuring unit incl. sender and magnetic base for installation with horizontal machining
- display facility with receiver
- measuring filter for measuring range up to 30 ml/h

Data interface and PC software are available as an option.



Guhring has developed a specific MQL test station for checking the perfect functioning of MQL tools. The inspection includes the following:

- response time of the initial aerosol exit
- time for constant aerosol flow
- whether MQL process runs with constant oil volume

The MQL test station offers the possibility of checking tools for 1- channel MQL systems as well as 2-channel MQL systems. There is the possibility of numerous options with regard to speed, MQL volume and air pressure. Subsequently, it is possible to check whether the lubricating medium exits evenly from the coolant ducts in order to ensure a sufficient lubrication of the cutting edges. If necessary, the coolant ducts can be modified accordingly.

Thanks to freely accessible tool clamping modifications to the MQL systems only take a few minutes.

A mounted motor spindle with automatic tool clamping enables realistic inspection conditions. Thus, the MQL test station can be operated at a working speed up to 16,000 min<sup>-1</sup>.

With the assistance of the records of the test station, the functionality of the tool lubrication can be optimised and documented for the customer. The application of Guhring's test station increases process reliability and optimises manufacturing efficiency.

MQL - PERFORMANCE TEST

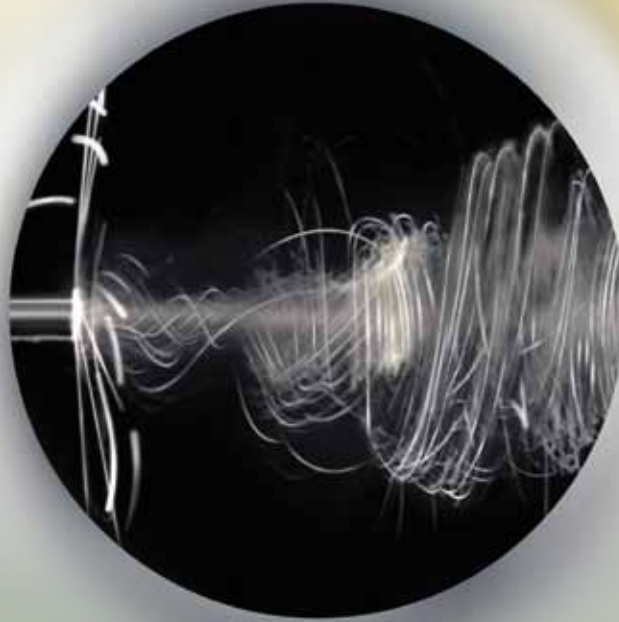

**MQL**  
BY GÜHRING

RESEARCH & DEVELOPMENT

**Guehring KG**  
P.O. Box 100247 | 72458 Albstadt  
Tel.: +49 74 31 17 - 0 | Fax: +49 74 31 17 - 21 279  
info@guehring.de | www.guehring.de